

IP interface  
Code: EK-BB1-TP  
IP router  
Code: EK-BC1-TP

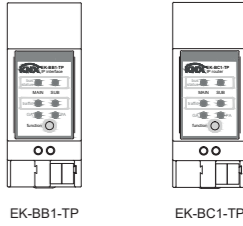

Instructions



EK-BB1-TP

EK-BC1-TP

**EKINEX S.p.A.**

Via Novara 37  
I-28010 Vaprio d'Agogna (NO), Italia  
Tel. +39 0321 1828980  
info@ekinex.com  
www.ekinex.com

FISPBBC1XTPIEX0

**Warnings**

- Installation, electrical connection, configuration and commissioning of the device can only be carried out by qualified personnel in compliance with the applicable technical standards and laws of the respective countries
- Opening the housing of the device causes the immediate end of the warranty period
- In case of tampering, the compliance with the essential requirements of the applicable directives, for which the device has been certified, is no longer guaranteed
- ekinex® KNX defective devices must be returned to the manufacturer at the following address: EKINEX S.p.A. Via Novara 37, I-28010 Vaprio d'Agogna (NO) Italy

**Other information**

- The instruction sheet must be delivered to the end customer with the project documentation
- For further information on the product, please contact the ekinex® technical support at the e-mail address: support@ekinex.com or visit the website www.ekinex.com
- KNX® and ETS® are registered trademarks of KNX Association cvba, Brussels

© EKINEX S.p.A. The company reserves the right to make changes to this documentation without notice.

**Configuration and commissioning**

Configuration and commissioning of the device require the use of the ETS® (Engineering Tool Software) program V5 or later releases. These activities must be carried out according to the design of the building automation system done by a qualified planner.



*Note. The configuration and commissioning of KNX devices require specialized skills. To acquire these skills, you should attend the workshops at KNX certified training centers.*

**Configuration**

For the configuration of the device parameters the corresponding application program or the whole ekinex® product database must be loaded in the ETS® program. For detailed information on configuration options, refer to the application manual of the device available on the website www.ekinex.com.

Product code	Application software (## = release)
EK-BB1-TP	APEKBB1TP##.knxprod
EK-BC1-TP	APEKBC1TP##.knxprod

**Commissioning**

For commissioning the device the following activities are required:

- make the electrical connections as described above;
- turn on the bus power supply;
- switch the device operation to the programming mode by pressing the programming pushbutton located on the front side of the housing. In this mode of operation, the programming LED is turned on;
- download into the device the physical address and the configuration with the ETS® program.

At the end of the download the operation of the device automatically returns to normal mode; in this mode the programming LED is turned off. Now the bus device is programmed and ready for use.

**Marks**

- KNX
- CE: the device complies with the Low Voltage Directive (2014/35/EU) and the Electromagnetic Compatibility Directive (2014/30/EU).

**Maintenance**

The device is maintenance-free. To clean use a dry cloth. It must be avoided the use of solvents or other aggressive substances.

**Disposal**



At the end of its useful life the product described in this datasheet is classified as waste from electronic equipment in accordance with the European Directive 2012/19/EU (WEEE), and cannot be disposed together with the municipal undifferentiated solid waste.



*Warning! Incorrect disposal of this product may cause serious damage to the environment and human health. Please be informed about the correct disposal procedures for waste collecting and processing provided by local authorities.*

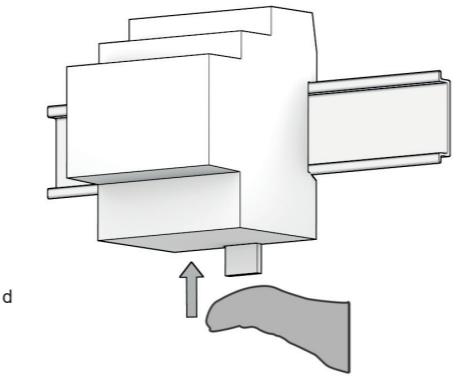

*Note. When mounting the device in boards and cabinets it shall be provided the necessary ventilation so that the temperature can be kept within the operating range of the device.*

**Connection of the KNX bus line**

The connection to the KNX bus line is made by the terminal blocks (black/red) included in the supply and inserted into the slots located on the bottom part of the front.

The connection to the LAN line is made via the RJ45 terminal connected to an Ethernet cable (minimum category 5E – not supplied).



*Warning! In order to supply the KNX bus lines use only KNX bus power supplies (e.g. ekinex EK-AB1-TP or EK-AG1-TP). The use of other power supplies can compromise the communication and damage the devices connected to the bus.*

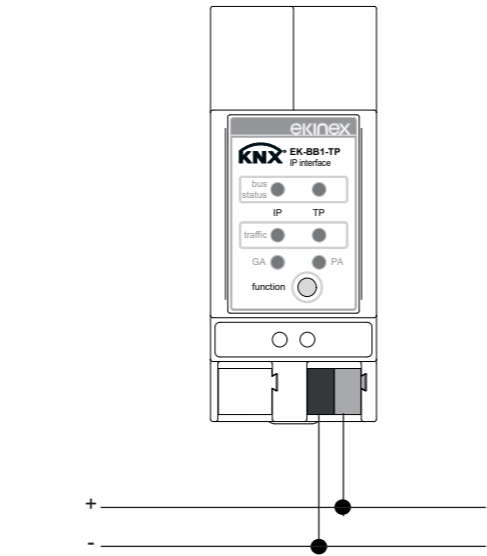

**Characteristics of the KNX terminal block**

- Spring clamping of conductors
- 4 seats for conductors for each polarity
- Terminal suitable for KNX bus cable with single-wire conductors and diameter between 0.6 and 0.8 mm
- Recommended wire stripping approx. 5 mm
- Color codification: red = + (positive) bus conductor, black = - (negative) bus conductor



*Warning! The electrical connection of the device can be carried out only by qualified personnel. The incorrect installation may result in electric shock or fire. Before making the electrical connections, make sure the power supply has been turned off.*

**Command elements**

- Function pushbutton (B)
- Long press (3 seconds): switch to manual control. The default function is set with LAN line and KNX line parameters through ETS.
- Very long press (15 seconds): all LEDs are red. Release button and press again for some seconds: resets all the parameter to factory default (incl. physical address).

**Display elements**

- LAN status LED (1)
  - off: LAN error or line not connected
  - on (green): LAN normal operation
  - on (red): manual override active
- KNX status LED (2)
  - off: KNX error or line not connected
  - on (green): KNX normal operation
- LAN traffic LED (3)
  - off: no data exchange on LAN line
  - blinking (green): data exchange active on LAN
  - blinking (red): LAN transmission error
- KNX traffic LED (4)
  - off: no data exchange on KNX line
  - blinking (green): data exchange active on KNX
  - blinking (red): KNX transmission error

**Mounting**

The device has degree of protection IP20, and is therefore suitable for use in dry interior rooms. The housing is made for rail mounting according to EN 60715 in boards or cabinets for electrical distribution. The installation is in horizontal position; the correct position is when the KNX bus terminal is located at the bottom. For the installation of the device on the rail proceed as follows:

- with the aid of a tool bring the locking device in the fully lowered position (a);
- place the upper edge of the rear inner profile on the upper edge of the rail (b);
- rotate the device towards the rail (c);
- push the locking device upward until it stops (d).

Before removing the device, be sure the bus terminals have been extracted from their slots. Use a screwdriver to slide down the locking device and remove the device from the rail.

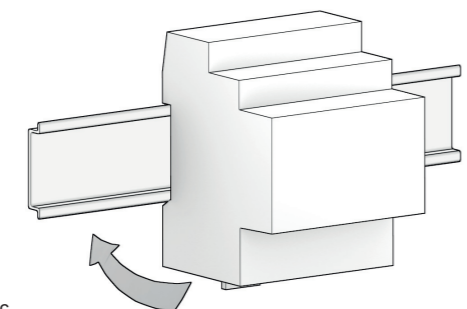
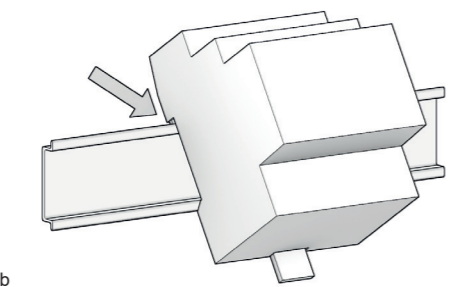
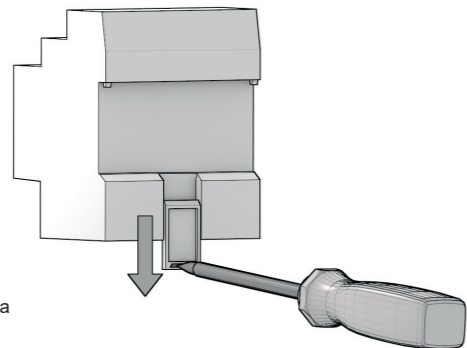

a

b

c

**Description**

**IP interface**

The ekinex® EK-BB1-TP IP interface realizes the bidirectional data link between a PC or laptop and a KNX system via LAN. The interface supports IP tunneling protocol and enables addressing, setting parameters, viewing and diagnosis of KNX devices via ETS. The device has an integrated KNX bus communication module and is designed for 35mm rail mounting. Power is supplied via the KNX bus.

**IP router**

The ekinex® EK-BC1-TP IP router realizes the bi-directional data link between a PC or laptop and a KNX system via LAN. The interface supports IP tunneling protocol and enables addressing, setting parameters, viewing and diagnosis of KNX devices via ETS. The IP router also integrates the function of a line coupler; telegrams can be exchanged between TP bus lines through a bridge over TCP/IP. The device has an integrated KNX bus communication module and is designed for 35mm rail mounting. The device is powered by a 30 Vdc SELV voltage via the KNX bus and does not require auxiliary power but, when sizing the bus line, you need to consider this as a supply equivalent to 4 devices of 10 mA.

**Function**

- Line coupler
- KNX bus status
- Ethernet bus status
- IP router sends telegrams from / to KNX from / to IP network
- Programmable plant via software ETS® remotely (IP router)

**Main characteristics**

- Housing in plastic material
- Mounting on 35 mm rail (according to EN 60715)
- Protection degree IP20 (installed device)
- Safety class II
- Weight 70 g
- 2 modular units (1 unit = 18 mm)
- Dimensions 36 x 90 x 70 mm (WxHxD)

**Technical data**

**Connections**

- 30 Vdc from KNX bus line
- Current consumption (from main bus line) ca. 10 mA
- RJ45 ethernet connector

**Environmental conditions**

- Operating temperature: - 5 ... + 45°C
- Storage temperature: - 20 ... + 60°C
- Transport temperature: - 20 ... + 60°C
- Relative humidity: 5 - 95% not condensing

**Switching, display and connection elements**

The device is equipped with 6 LEDs, a function pushbutton, 2 terminals for connecting the KNX bus lines, a programming LED and a programming pushbutton.

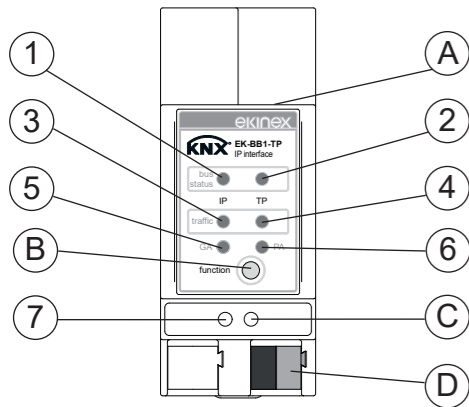

- 1. LAN status LED
- 2. KNX status LED
- 3. LAN traffic LED
- 4. KNX traffic LED
- 5. Not used
- 6. Not used
- 7. Programming LED
- A. Ethernet connector
- B. Function pushbutton
- C. Programming pushbutton
- D. KNX bus connector