

## Air quality multisensor and regulator

Codes: EK-ES2-TP (for round or square wall box)  
EK-ES2-TP-R (for rectangular wall box)



Datasheet STEKES2TP\_EN

KNX thermostat with temperature, relative humidity and CO<sub>2</sub> equivalent sensors, for the independent thermal regulation of a room or a zone. It has to be used in KNX installations for control of homes and buildings.

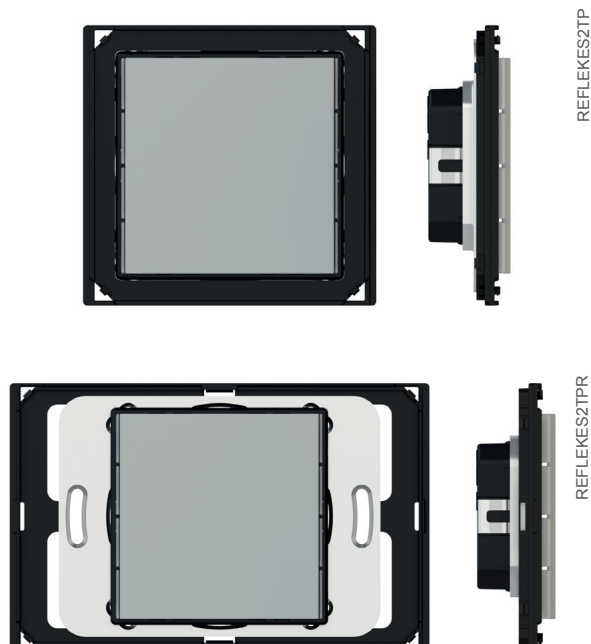

### Description

The ekinex® EK-ES2-TP... air quality multisensor and room temperature controller is a KNX S-mode device for the independent temperature regulation of a room or a zone in a building. It can be installed in houses and buildings (e.g., offices, hotels, private houses, etc.). The room temperature controller is equipped with 3 sensors: temperature, relative humidity and air quality, in terms of TVOC (Total Volatile Organic Compounds) or CO<sub>2</sub> equivalent. It can also work as a controller for these 3 parameters, that are available for a single zone to be managed. Up to 8 LEDs can be configured, in order to display the operating thresholds for the TVOC or CO<sub>2</sub> equivalent, the activation of the humidification/dehumidification functionality and the cooling/heating working modes. The device is equipped with an integrated KNX bus communication module and is designed for wall installation on a flush mounting box. Both the programming button and LED are located in



**Note.** The rocker and the frame (when necessary) for the completion of the device must be ordered separately. For more information on materials, colors and finishes available, see also the ekinex® product catalog or browse [www.ekinex.com](http://www.ekinex.com)

the front of the device below the rocker, as well as the 3 sensors. The device is powered by the KNX bus line and does not require any auxiliary power supply.

### Main functional characteristics

The common features to all versions are documented as follows:

- Temperature, relative humidity and air quality (TVOC and CO<sub>2</sub> equivalent) measuring through the integrated sensors, with possibility of sending the read value on the bus;
- Two-point (ON/OFF) or proportional (PWM or continuous) room temperature regulation;
- Seasonal modes: heating and cooling with possibility of either local or via bus seasonal changeover;
- Operating modes: comfort, standby, economy and building protection with different setpoint for heating and cooling functions;
- Automatic switching of the operating modes through presence sensor or window contact;
- Weighted average of two temperature values;
- Dew-point temperature computation;
- Temperature regulation (measured and setpoint, as °C), relative humidity (measured and setpoint in percentage), air quality in terms of TVOC (ppb) or CO<sub>2</sub> equivalent (ppm) concentration, alarms and errors (with alphanumeric coding);
- Relative humidity thresholds setting;
- TVOC and CO<sub>2</sub> equivalent thresholds setting, with the possibility to enable an alarm function for CO<sub>2</sub> threshold;
- Floor temperature limitation and antincondensation (for radiant panels);
- Delayed start of a fan ("hot-start") with time-scheduling or depending on the water temperature measured at the coil for thermal exchange;
- Compatibility with KNX actuators, for VAV flow regulators and 6-way zone valve management;
- Logic functions (AND, OR, NOT and XOR) availability, in order to implement complex functions.

### Other characteristics

- Plastic casing for wall mounting
- Integrated temperature, relative humidity and air quality (CO<sub>2</sub> equivalent) sensors
- Protection degree IP20 (according to EN 60529)
- Classification climatic 3K5 and mechanical 3M2 (according to EN 50491-2)
- Pollution degree 2 (according to IEC 60664-1)
- Weight (with mounting support): 70 g (round box), 100 g (rectangular box).

### Technical data

- Power supply 30 Vdc from KNX bus line
- Current consumption < 13 mA
- Max power from bus < 390 mW
- TVOC output values: 0 ÷ 60000 ppb
- CO<sub>2</sub> output values: 400 ÷ 60000 ppm

### Environmental conditions

- Operating temperature: -5 ... +45°C
- Storage temperature: -25 ... +55°C
- Transport temperature: -25 ... +70°C
- Relative humidity: 95% not condensing

### Accessories

A metallic support, the fixing screws and the terminal for connection of the KNX bus line are delivered with the device. This has to be completed with the following items:

- a square rocker 60 x 60 mm, with set code EK-T1Q-..., to be filled with the specific colour and material exten-

- a single plate and a frame, to be ordered separately, except for the 'NF (No Frame) version, which do not require any frame.

## Plate

The room temperature controller may be completed by a square 1-fold plate or by a rectangular 2-fold plate. In both cases the plate must be necessarily provided with a 60 x 60 mm window for the mounting of the device.

Plate code *	Type	Appearance	Window modularity [mm]
EK-PQS-...	1-fold **		60 x 60
EK-PRS-...	1-fold **		60 x 60
EK-P2G-...	2-fold ***		55 x 55 (1) 60 x 60 (1)
EK-P2S-...	2-fold ***		60 x 60 (2)

(\*) To be completed with the extension for colour, material and finishing  
 (\*\*) For mounting without frame ('NF') it requires the EK-TAQ adapter  
 (\*\*\*) For mounting without frame ('NF') it requires the EK-A71-... adapter

## Frame

The room temperature controller can be completed by a square 1-fold frame or by a rectangular 2-fold frame of the flank or form series. The 'NF (No Frame) versions of the pushbutton do not require any frame.

## Mounting

The device has degree of protection IP20, and is therefore suitable for use in dry interior rooms. The installation of the device requires the following steps:

### Mounting with frame, round flush-mounting box

Carry out the following steps:

- fix the metallic support (h) with the screws (g) on a flush-mounting box (i) provided with suitable fixing holes;

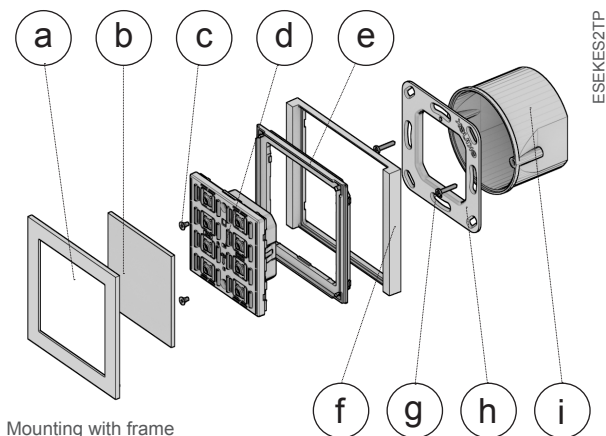

Mounting with frame

- a) 1-fold plate (square, with 60 x 60 mm window)
- b) Rocker
- c) Screws (for device)
- d) Device
- e) Adapter (delivered preassembled on the device)
- f) Frame (square, form or flank series)
- g) Screws (for metallic support)
- h) Metallic support
- i) Flush-mounting box (not delivered by ekinex®)

- snap a square frame (f) of the form or flank series, inserting it from the rear of the preassembled thermostat-adapter (d+e);
- insert the bus terminal, previously connected to the bus cable, in its slot on the rear side (see also: "Connection of the KNX bus line"). At this point it is recommended to carry out the commissioning of the pushbutton (see also "Configuration and commissioning") or at least the download of the physical address;
- insert thermostat and adapter (d+e), completed with the frame (f), in the metallic support (h). Mounting the pushbutton follow the indication TOP (arrow tip pointing up) on the rear side of the device;
- tighten thermostat, adapter and frame (d+e+f) on the metallic support (h) with the two screws (c);
- snap the plate (a);
- snap the rocker (b) to complete the installation.

### Mounting with no frame, round flush-mounting box

Carry out the following steps:

- insert the metallic support (f) on the adapter (g);
- fix adapter and metallic support (f+g) with the screws (e) on a flush-mounting box (h) provided with suitable fixing holes;
- insert the bus terminal, previously connected to the bus cable, in its slot on the rear side (see also: "Connection of the KNX bus line"). At this point it is recommended to carry out the commissioning of the pushbutton (see also "Configuration and commissioning") or at least the download of the physical address;
- insert the thermostat (d) in the support-adapter (f+g). Mounting the device follow the indication TOP (arrow tip pointing up) on the rear side of the device;
- tighten the device on the support-adapter (f+g) with the two screws (c);
- snap the plate (a);
- snap the rocker (b) to complete the installation.

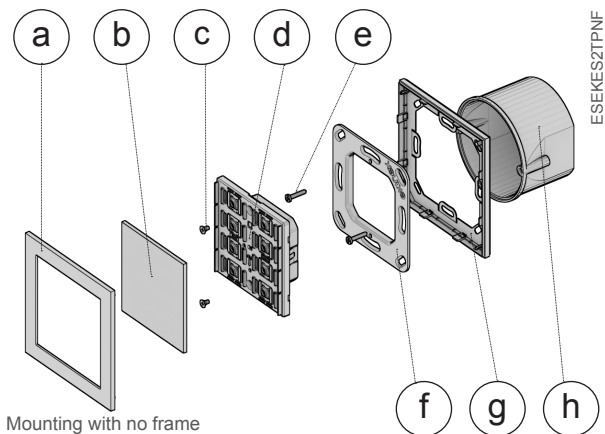

Mounting with no frame

- a) 1-fold plate (square, with 60 x 60 mm window)
- b) Rocker
- c) Screws (for device)
- d) Device
- e) Screws (for metallic support)
- f) Metallic support
- g) Adapter for 'NF' series (delivered with the device)
- h) Flush-mounting box (not delivered by ekinex®)

### Mounting with rectangular flush-mounting box

Carry out the following steps:

- insert the metallic support (f) on the adapter (g);
- for versions provided with frame only: snap a rectangular frame (f) of either form or flank series, starting from the back side of the support-adapter group (f+g) ;
- fix adapter and metallic support (f+g) (and eventually the frame, h) with the screws (e) on a flush-mounting box (i) provided with suitable fixing holes;

- insert the bus terminal, previously connected to the bus cable, in its slot on the rear side (see also: “Connection of the KNX bus line”). At this point it is recommended to carry out the commissioning of the pushbutton (see also “Configuration and commissioning”) or at least the download of the physical address;
- insert the thermostat (d) in the support-adapter (f+g). Mounting the device follow the indication TOP (arrow tip pointing up) on the rear side of the device;
- tighten the device on the support-adapter (f+g) with the two screws (c);
- snap the plate (a);
- snap the rocker (b) to complete the installation.

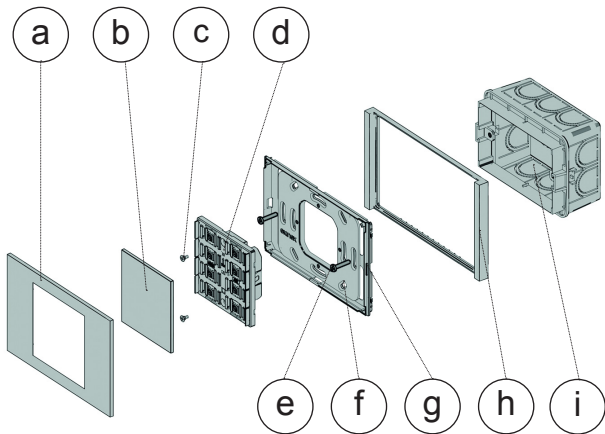

- a) 1-fold plate (square, with 60 x 60 mm window)
- b) Rocker
- c) Screws (for device)
- d) Device
- e) Screws (for metallic support)
- f) Metallic support
- g) Plastic adapter
- h) Rectangular frame (not for NF version)
- i) Flush-mounting box (not delivered by ekinex®)

### Mounting position

For optimum regulation the device has to be preferably installed on an internal wall at the height of 1.5 m and at least 0.3 m far from doors. The device cannot be installed close to heat sources such as radiators or domestic appliances or in positions subject to direct sunlight. If necessary, for the regulation may be used a weighted average between two values selected among the following ones: value measured by the internal sensor, value measured by a temperature sensor connected to a device input, value received via bus by another KNX device (e.g. from ekinex pushbuttons).

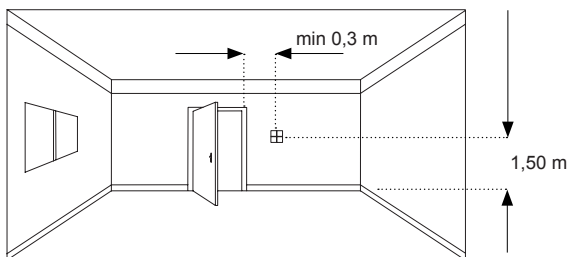

### Switching, display and measuring elements

The device is equipped with a programming LED, 8 displaying LEDs with lightguides for feedback status and 3 sensors.

#### Switching elements

- Pushbutton (13) for switching between the normal and programming operating mode.

#### Display elements

- White LED for indication of the heating mode functionality active, red if heating is ON (4);
- White LED for indication of the cooling mode functionality active, blue if cooling is ON (5);
- Blue LED (6) for indication of the dehumidification functionality ON;
- Green LED (7) for indication of the humidification functionality ON;
- Red (flashing) LED for indication that the measured CO<sub>2</sub> eq. exceeds threshold 3, orange if it lies between threshold 2 and 3 (8);
- Yellow LED for indication that the measured CO<sub>2</sub> eq. lies between threshold 1 and 2, green if it is below threshold 1 (9);
- Red (flashing) LED for indication that the measured TVOC exceeds threshold 3, orange if it lies between threshold 2 and 3 (10);
- Yellow LED for indication that the measured TVOC lies between threshold 1 and 2, green if it is below threshold 1 (11);
- Red (flashing) LED (12) for indication of the active operating mode (on = programming, off = normal operation).

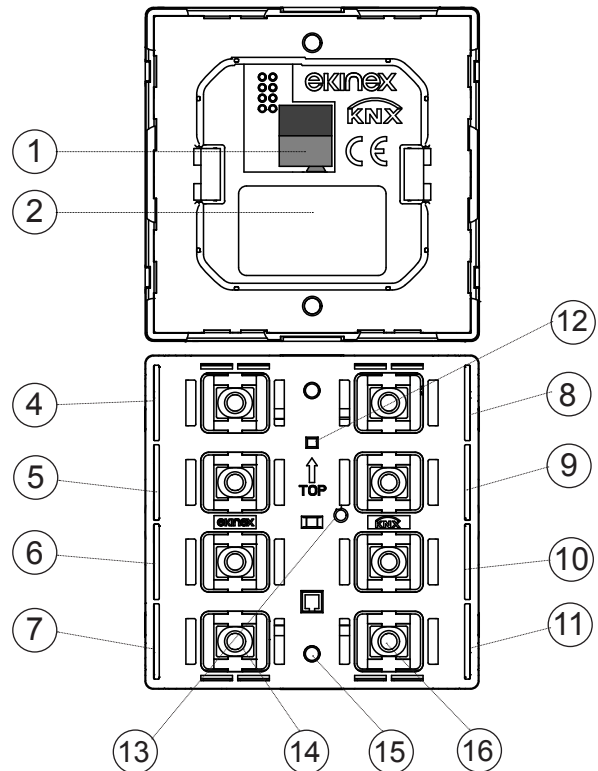

- 1) Terminal block for KNX bus line
- 2) Product label
- 3) Adapter
- 4) White LED (Thermostat status = heating) or red LED (heating ON)
- 5) White LED (Thermostat status = cooling) or blue LED (cooling ON)
- 6) Blue LED (dehumidification ON)
- 7) Green LED (humidification ON)
- 8) Red flashing LED (CO<sub>2</sub> equivalent concentration > threshold 3) or orange LED (CO<sub>2</sub> eq. concentration between threshold 2 and 3)
- 9) Yellow LED (CO<sub>2</sub> eq. concentration between threshold 1 and 2) or green LED (CO<sub>2</sub> eq. concentration below threshold 1)
- 10) Red flashing LED (TVOC concentration > threshold 3) or orange LED (TVOC concentration between threshold 2 and 3)
- 11) Yellow LED (TVOC concentration between threshold 1 and 2) or green LED (TVOC concentration below threshold 1)
- 12) Programming LED
- 13) Programming pushbutton
- 14) Relative humidity sensor
- 15) Temperature sensor
- 16) TVOC and CO<sub>2</sub> equivalent sensor



**Note.** Programming pushbutton and LED are accessible from the front side of the device. The device addressing may be easily carried out after the assembly of the frame, removing the rockers. Once the addressing has been done, the device configuration can be later downloaded without pressing the programming pushbutton.

LED flashes if the CO<sub>2</sub> equivalent alarm function is active and the configured maximum threshold value is exceeded.

If the building is subjected to sustainability certification according to the LEED protocol (Leadership in Energy and Environmental Design, by the US Green Building Council), the setting of the function can be useful to get the EQ Credit (Advanced strategies for indoor air quality) with reference to requirement C (carbon dioxide monitoring).

For measuring purposes the device is equipped with:

- a relative humidity sensor (14);
- a temperature sensor (not visible, positioned behind the passage 15);
- a TVOC / CO<sub>2</sub> equivalent air quality sensor (16).

### Connection of the KNX bus line

The connection of the KNX bus line is made with the terminal block (black/red) included in delivery and inserted into the slot of the housing.

#### Characteristics of the KNX terminal block

- spring clamping of conductors
- 4 seats for conductors for each polarity
- terminal suitable for KNX bus cable with single-wire conductors and diameter between 0.6 and 0.8 mm
- recommended wire stripping approx. 5 mm
- color codification: red = + (positive) bus conductor, black = - (negative) bus conductor



**Warning!** In order to supply the KNX bus lines use only KNX bus power supplies (e.g. ekinex EK-AB1-TP or EK-AG1-TP). The use of other power supplies can compromise the communication and damage the devices connected to the bus.

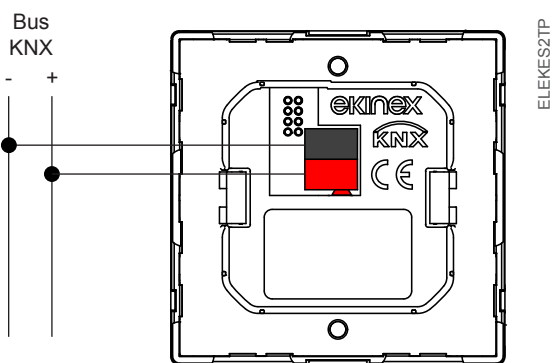

### Configuration and commissioning

Configuration and commissioning of the device require the use of the ETS® (Engineering Tool Software) program V4 or later releases. These activities must be carried out according to the design of the building automation system done by a qualified planner.



**Warning!** The electrical connection of the device can be carried out only by qualified personnel. The incorrect installation may result in electric shock or fire. Before making the electrical connections, make sure the power supply has been turned off.

### Configuration

For the configuration of the device parameters the corresponding application program or the whole ekinex® product database must be loaded in the ETS program. For detailed information on configuration options, refer to the application manual of the device available on the website [www.ekinex.com](http://www.ekinex.com).



**Note.** The configuration and commissioning of KNX devices require specialized skills. To acquire these skills, you should attend the workshops at KNX certified training centers.

Code	Application program (## = release)	Comm. objects (max nr.)	Group addr. (max nr.)
EK-ES2-TP	APEKES2TP##.knxprod	150	254

### Commissioning

For commissioning the device the following activities are required:

- make the electrical connections as described above;
- turn on the bus power supply;
- switch the device operation to the programming mode by pressing the programming pushbutton located on the front side in the area for the mounting of the rockers. In this mode of operation, the programming LED is turned on;
- download into the device the physical address and the configuration with the ETS® program.

At the end of the download the operation of the device automatically returns to normal mode; in this mode the programming LED is turned off. Now the bus device is programmed and ready for use.

### Dimensions [mm]

Thermostat for round flush-mounting box

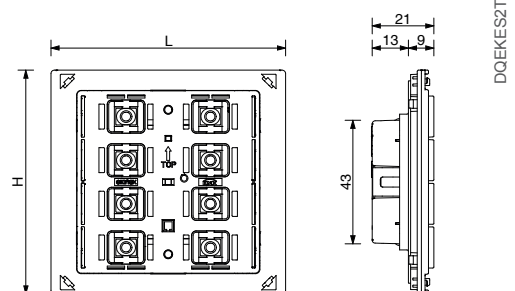

Version	Dimensions L x H [mm]
frame mounting	81 x 77
no-frame mounting	80 x 80

Thermostat for rectangular flush-mounting box

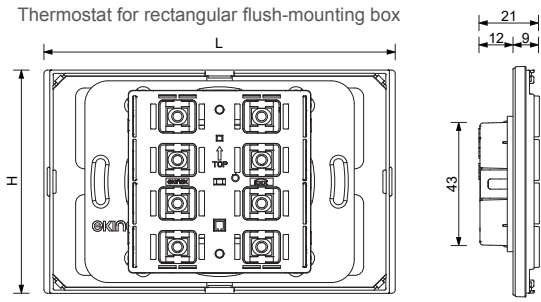

DQEKES2TPR

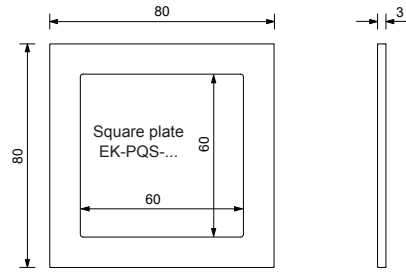

Version	Dimensions L x H [mm]
frame mounting	122 x 77
no-frame mounting	121 x 80

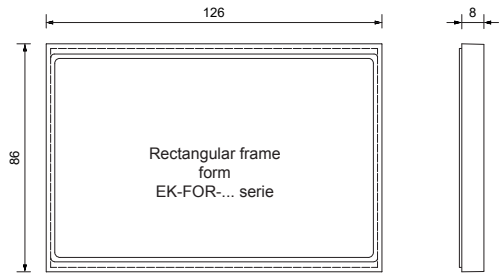

Rocker

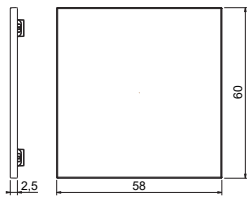

DQFASTI71

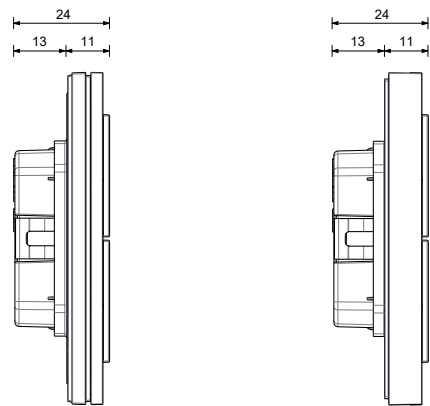
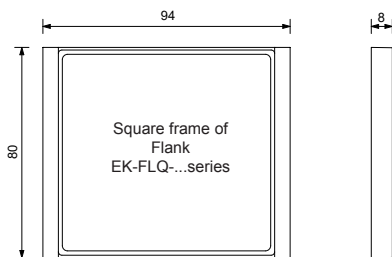
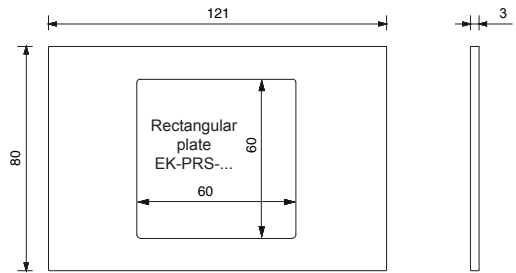
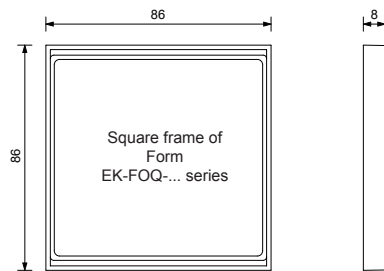
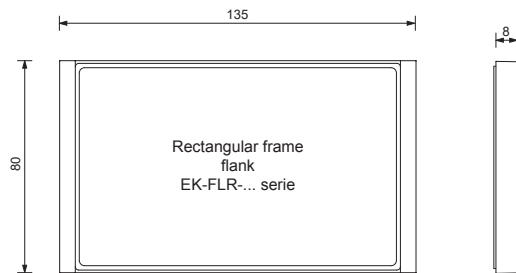

EK-ES2-TP Thermostat for no-frame mounting (NF series), completed with rocker and plate EK-PQS-...

EK-ES2-TP Thermostat of either Form or Flank series, completed with rocker and plate EK-PQS-...

## Marks

- KNX
- CE: the device complies with the Low Voltage Directive (2014 / 35 / EU) and the Electromagnetic Compatibility Directive (2014 / 30 / EU). Tests carried out according to EN 50491-5-1:2010 and EN 50491-5-2:2010

- KNX® and ETS® are registered trademarks of KNX Association cvba, Brussels

© Ekinex® S.p.A. The company reserves the right to make changes to this documentation without notice.

## Maintenance

The device is maintenance-free. To clean use a dry cloth. It must be avoided the use of solvents or other aggressive substances.

## Disposal



At the end of its useful life the product described in this datasheet is classified as waste from electronic equipment in accordance with the European Directive 2012 / 19 / EU (WEEE recast), and cannot be disposed together with the municipal undifferentiated solid waste



**Warning!** Incorrect disposal of this product may cause serious damage to the environment and human health. Please be informed about the correct disposal procedures for waste collecting and processing provided by local authorities.

## Documentation

This datasheet refers to the release A1.0 of the ekinex® device EK-ES2-TP... is available for download at [www.ekinex.com](http://www.ekinex.com) as a PDF (Portable Data Format) file.

File name	Device release	Updating
STEKES2TPR01_EN.pdf	1.0	01 / 2020

## Warnings

- Installation, electrical connection, configuration and commissioning of the device can only be carried out by qualified personnel in compliance with the applicable technical standards and laws of the respective countries
- Opening the housing of the device causes the immediate end of the warranty period
- In case of tampering, the compliance with the essential requirements of the applicable directives, for which the device has been certified, is no longer guaranteed
- ekinex® KNX defective devices must be returned to the manufacturer at the following address: Ekinex® S.p.A. Via Novara 37, I-28010 Vaprio d'Agogna (NO) Italy

## Other information

- This datasheet is aimed at installers, system integrators and planners
- For further information on the product, please contact the ekinex® technical support at the e-mail address: [support@ekinex.com](mailto:support@ekinex.com) or visit the website [www.ekinex.com](http://www.ekinex.com)
- Each ekinex® device has a unique serial number on the label. The serial number can be used by installers or system integrators for documentation purposes and has to be added in each communication addressed to the ekinex® technical support in case of malfunctioning of the device

## Annex 1. Installation

The EK-ES2-TP... room temperature controller comes with an integrated KNX communication module. It is suitable for mounting into a flush-mounting box, either round (t) or square (u), provided with fixing holes 60 mm apart. It can also be installed into a rectangular wall mounting box (v) 3-seater according to the Italian installation standard provided with fixing holes 83,5 mm apart. Each thermostat is delivered with its metal support (i, k) which, in case of necessity, can also be ordered separately. A plastic adapter and a terminal block complete the supply.

The thermostat must be finished off with an operation surface (rocker), a plate with 60 x 60 mm window and a frame. The rocker (i) is available in a square shape, in plastic material and in three different colours.

Each device has integrated eight displaying LEDs with lightguides for feedback status and 3 sensors. The square (r, r1) and rectangular (s, s1) frames are available in two stylish alternatives (form and flank) and share the same choice of materials, colours and finishes as for rocker.

The 'NF' versions of the device are mounted without frame and are provided with a side profile in white or black colour.

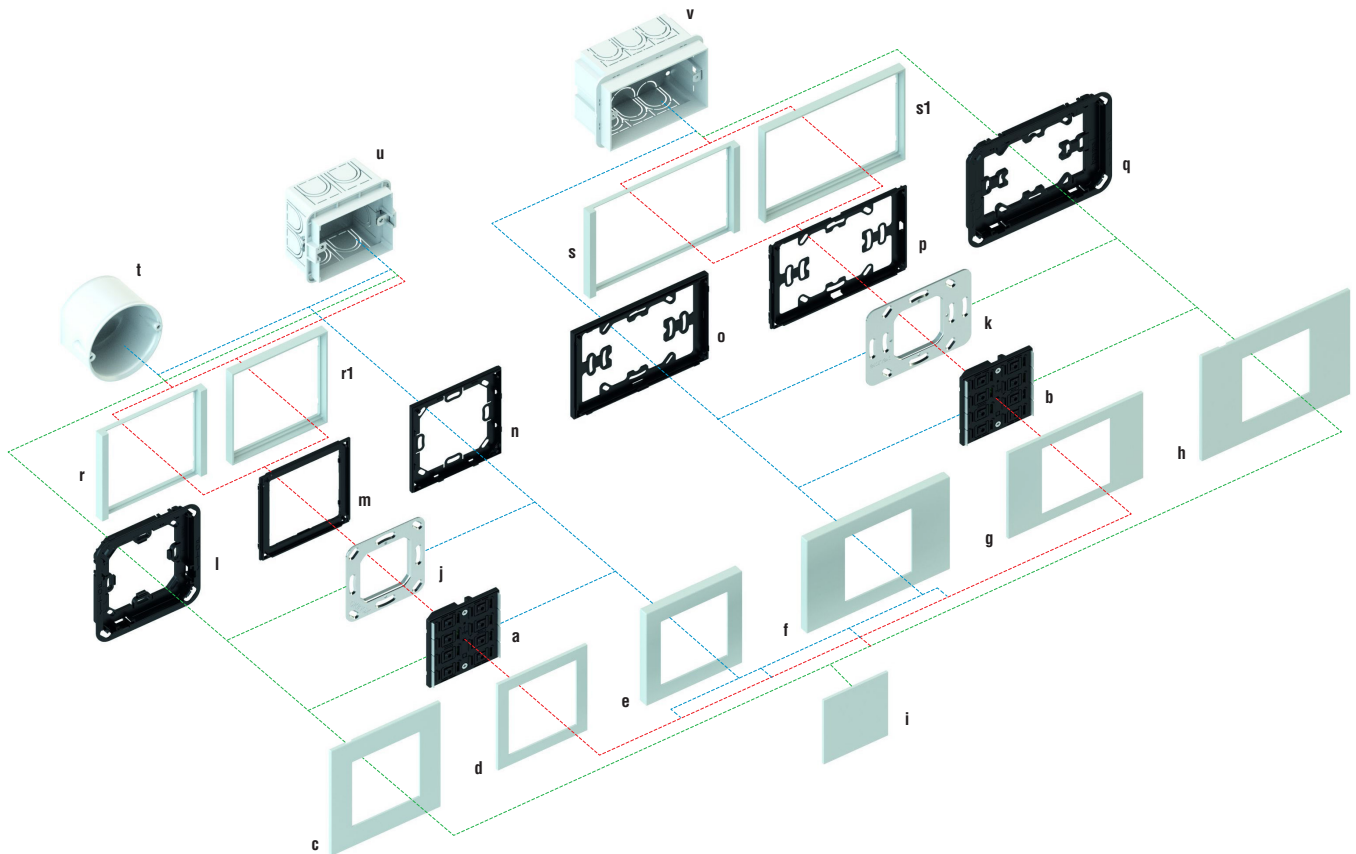

## Legenda

Description	Code
a) Thermostat EK-ES2-TP for square flush-mounting box	EK-ES2-TP
b) Thermostat EK-ES2-TP-R for rect. flush-mounting box	EK-ES2-TP-R
c) Square plate Surface series*	EK-SQS-...
d) Square plate*	EK-PQS-...
e) Square plate Deep series*	EK-DQP-...
f) Rectangular plate Deep series*	EK-DRS-...
g) Rectangular plate*	EK-PRS-...
h) Rectangular plate Surface series*	EK-SRS-...
i) Square rocker	EK-T1Q-...
j) Metal mounting support	EK-SMQ-71
k) Metal mounting support with adapter	EK-SMR-71**
l) Adapter for square Surface plate	EK-TAS-Q-...-NF
m) Adapter for square plate**	EK-TAQ-...

Description	Code
n) Adapter for square plate 'NF and Deep series	EK-TAQ-...-NF
o) Adapter for rectangular plate 'NF and Deep series	EK-TAR-...-NF
p) Adapter for rectangular plate**	EK-TAR**
q) Adapter for Surface rectangular plate	EK-TAS-R-...
r) Square frame Flank series	EK-FLQ-...
r1) Square frame Form series	EK-FOQ-...
s) Rectangular frame Flank series	EK-FLR-...
s1) Rectangular frame Form serie	EK-FOR-...
t) Round flush-mounting box	not delivered by ekinex®
u) Square flush-mounting box	not delivered by ekinex®
v) Rectangular flush-mounting box (3 modules)	not delivered by ekinex®
*) 60 x 60 mm window	
**) Included in the supply of the thermostat	

## Annex 2. Finalising

